

HYBRID



Pizza Capacity

8" pizza Capacity: 7-8

16" pizza Capacity: 3-4

Shipping Dimensions:

59" x 59" x 80"

Unit shipping:

Weight: 3,000 lbs.

Job name:

Item#:

Fuel type: Gas-Fired

Features

- Standard door opening: 20 ½ Inches wide x 9 inches high with stylish and functional stainless steel high efficiency doors.
- 40 square inch cooking surface which allows for the preparation of an array of foods - perfect for entertaining
- Hand made fire brick cooking floor and dome for high performance
- Contemporary in style while honoring the cooking characteristics that produce the distinctive flavor and crust of traditional Italian pizza
- All brick interior is heated by an adjustable flame burner in the rear of the oven floor
- Black granite hearth is standard
- Standard analog thermometer in the oven front monitors the temperature
- Turbo ventilating system circulates the smoke in the oven interior for maximum heat efficiency and performance
- Oven body and gas control panel are integrated within the oven's steel stand
- Only 1-inch side and back clearance to combustible building materials required
- CSA Listed for Commercial installation
- Built in the USA
- Steel Stand with two shelves for wood storage
- Oven features 4 " insulation blanketing the entire oven.
- 8" Stainless steel venting
- Mosaic or stucco finish
- Hybrid system gas /wood

Note: For more information on home oven configuration options, please visit: www.fornoclassico.com

Forno Classico Company, 53 Aero Camino Goleta CA USA

T. +1 (805) 895-2626

info@fornoclassico.com

www.fornoclassico.com



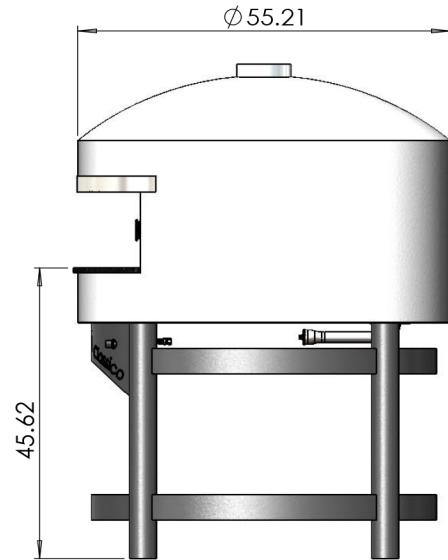
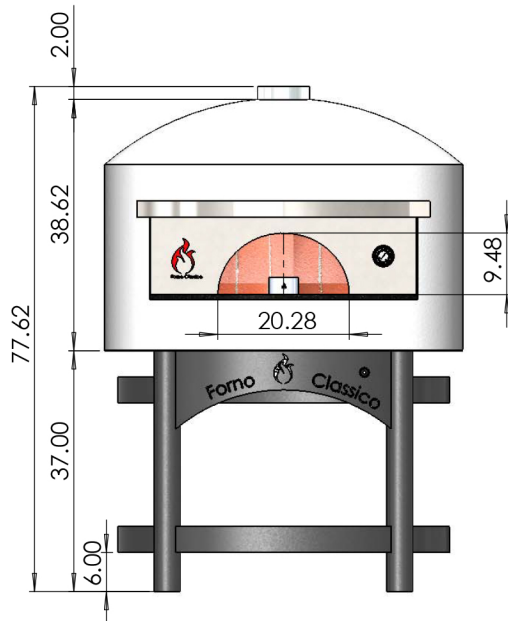
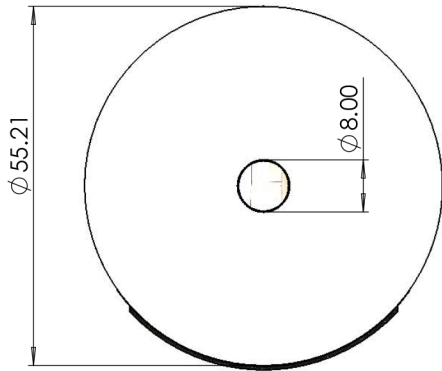

Gas Features

Gas connections ½" NPT per burner, quick disconnect flex gas hose must be used. - Pressure required 10" - 14" W.C. (Water Column) at the gas valve. • 64,000 BTU's per burner.

Venting

The oven is vented through an 8" round duct collar. The Neapolitan wood, gas, and combination gas-wood ovens can be installed with a listed exhaust hood system or with a chimney/grease duct vented outside without an exhaust hood, but must be installed with a power exhausted vent. • Cubic Feet per Minute: 150CFM • Static Pressure: 0.01"W

Forno Classico Company, 53 Aero Camino Goleta CA USA

T. +1 (805) 895-2626

info@fornoclassico.com

www.fornoclassico.com

