

HYBRID



Pizza Capacity

8'' pizza Capacity: 4-5

16'' pizza Capacity: 1

Shipping Dimensions:

40''x 40'' x 77''

Unit shipping:

Weight: 1,200 lbs.

Job name:

Item#:

Features

- Standard door opening: 16 Inches wide x 8 inches high with stylish and functional stainless steel high efficiency doors.
- 26 square inch cooking surface which allows for the preparation of an array of foods - perfect for entertaining
- Hand made fire brick cooking floor and dome for high performance
- Low brick dome for better performance
- Contemporary in style while honoring the cooking characteristics that produce the distinctive flavor and crust of traditional Italian pizza
- All brick interior is heated by an adjustable flame burner in the rear of the oven floor
- Black granite hearth is standard
- Standard analog thermometer in the oven front monitors the temperature
- Stainless Steel Door
- Turbo ventilating system circulates the smoke in the oven interior for maximum heat efficiency and performance
- Oven body and gas control panel are integrated within the oven's steel stand
- Only 1-inch side and back clearance to combustible building materials required
- CSA Listed for Commercial installation
- Built in the USA
- Steel Stand with shelves for wood storage
- Oven features 4 '' insulation blanketing the entire oven.
- 6'' Stainless steel venting
- Mosaic or stucco finish
- Hybrid system gas /wood

Note: For more information on home oven configuration options, please visit: www.fornoclassico.com

Forno Classico LLC Company, 53 Aero Camino Goleta CA USA

Tell. **1-888-337-2708**

info@fornoclassico.com

www.fornoclassico.com



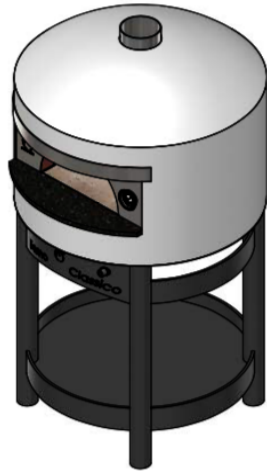

Gas Features

Gas connections 1/2" NPT per burner, quick disconnect flex gas hose must be used. Pressure required 10" - 14" W.C. (Water Column) at the gas valve. 50,000 BTU's No electricity required

Clearances

The oven shall be installed a minimum of 1" away from combustible material from back wall to oven and side wall to oven. You may bridge the gap between any wood framing and the oven by using metal framing with concrete board or masonry

Venting

The oven is direct vented with a 6" chimney pipe listed to the UL 103 HT standard. The chimney starts with an anchor plate and requires a minimum rise of 36" for the oven to properly draft. The Chimney must terminate to a UL listed spark arrestor installed 2' taller than any structure within a 10' radius. Venting is not included as it varies depending on installation requirements.

Note

The oven should be installed in accordance with all relevant local and national codes and in a manner acceptable to the authority having jurisdiction.

Progressive changes in technology and product development may necessitate changes to specifications without notice.

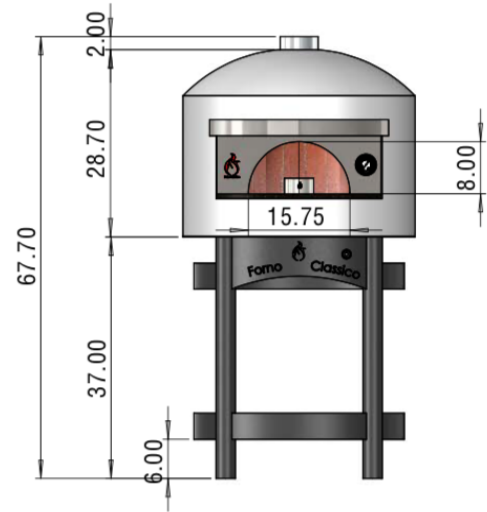

FRONT VIEW

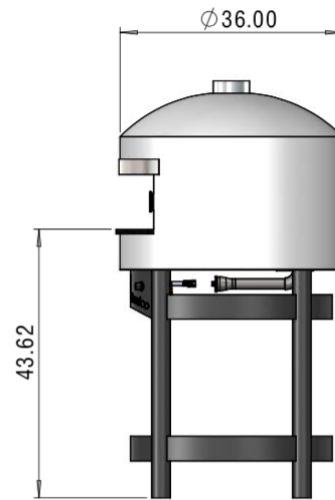

SIDE VIEW

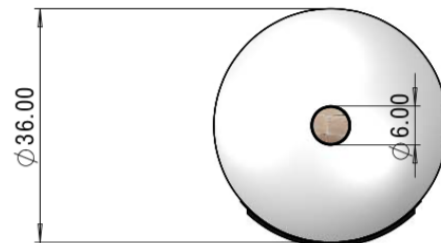

TOP VIEW